

CHEMGUARD High-Expansion Foam Generators

Features

- UL Listed and CE Marked
- LNG specific models available
- Water-powered so no electrical power is required
- Foam capacities of up to 27,552 cfm (780 cmm)

Application

CHEMGUARD High-Expansion Foam Generators are intended for use in total flooding or local application high-expansion foam systems. Total flooding high-expansion foam systems are commonly used to protect the following hazards:

- Flammable liquid storage areas
- Hazardous waste storage areas
- Ship holds
- Engine rooms

Local application foam systems are commonly used to protect aircraft hangars. High-expansion foam systems are also frequently used to protect LNG facilities. These systems are typically used to control the vaporization rate of LNG spills or reduce the intensity of LNG fires by controlling the rate of vapor release.

Note: High-expansion foam generators used in LNG applications typically require expansion ratios of approximately 500:1.

Description

CHEMGUARD High-Expansion Foam Generators produce large volumes of foam by coating a stainless steel perforated metal screen with high-expansion foam solution and expanding it with airflow generated by a water-powered fan. When used with CHEMGUARD C2 2% High-Expansion Foam Concentrate, these generators are capable of producing finished foam with expansion ratios from 332:1 up to 891:1, depending on the model and operating pressure.

Protective Coatings

All generator models are painted using a Corrosion Resistant Epoxy (Epoxy CR) paint system on the housings, supports, and guard screens. Fans are painted using a powder paint system to ensure adherence and paint durability. Both paint systems have been subjected to and passed a minimum of 3,000 hours in salt spray corrosion testing and are suitable for marine and offshore use. The stainless steel foam screens are not painted to avoid inhibiting foam production.

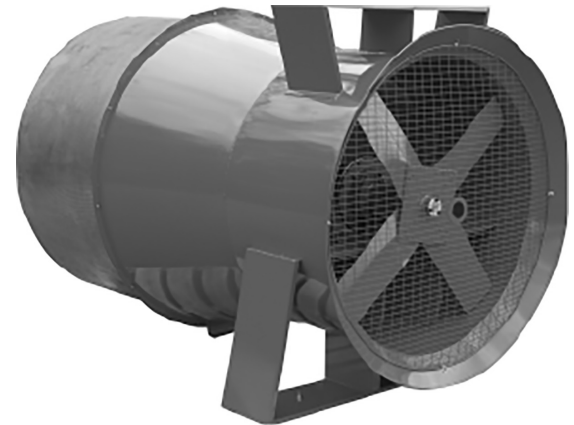

010367

Approvals and Certifications

UL Listed

CHEMGUARD High-Expansion Foam Generators are UL Listed for use with CHEMGUARD C2 2% High-Expansion Foam Concentrate.

CE Marked

All models are CE Marked in conformance with the Machinery Directive 2006/42/EC.

Operation and Maintenance

Refer to the CHEMGUARD High-Expansion Foam Generator Operation and Maintenance Manual for detailed procedures on installation, operation, and maintenance. A printed copy of this manual is included with every generator.

Foam Generator Components

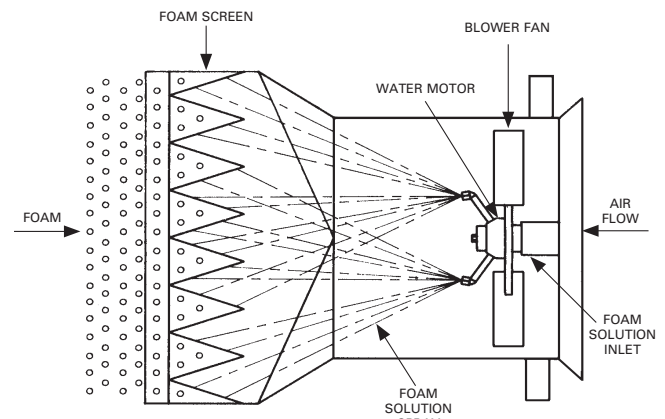

001274

Materials of Construction

CHEMGUARD High-Expansion Foam Generators are manufactured from a combination of carbon steel, stainless steel, and brass components. For materials of construction of the major components, see the following table:

Component	Material			
Model	Standard Models: CHX2000, CHX5000, CHX15000, CHX20000	Standard Models: CHX27000	LNG Models: CHX2000-SS-LNG, CHX5000-SS-LNG, CHX20000-SS-LNG	3000WP
Housing	Galvanized Steel	Galvanized Steel		Carbon Steel
Foam Screen	201, 302, or 304 SS	201, 302, or 304 SS	316 or 316L SS	304 SS
Fan	Carbon Steel*	Carbon Steel*	Carbon Steel*	304 SS Blades, 302 SS Rivets, Zinc Plated Carbon Steel or 304 SS Hub
Water Motor	Brass	Cast Iron/Bronze	Brass	Cast Iron/Bronze
Nozzle(s)	Brass	Brass	Brass	Brass

*Carbon Steel fans are powder painted with a durable, marine-grade paint system for corrosion resistance.

Performance Data

UL Listed Performance (Chemguard C2 2%)									
Generator Model	Material	Part Number	Inlet Pressure		Flow rate		Foam output		Expansion Ratio
			psi	bar	gpm	lpm	cfm	cmm	
3000WP	Carbon Steel	703603	40	2.8	57	216	2535	72	332
			50	3.4	58	220	3120	88	400
			60	4.1	60	227	3613	102	449
			70	4.8	63	238	4014	114	478
			80	5.5	67	254	4322	122	487
			90	6.2	72	273	4538	128	476
			100	6.9	78	295	4661	132	446
CHX2000	Carbon Steel	704775	40	2.8	32	121	1778	50	421
			50	3.4	35	132	2134	60	456
			60	4.1	38	144	2463	70	485
CHX2000-SS-LNG	Stainless Steel	704776	70	4.8	41	155	2666	75	485
			80	5.5	44	167	2880	82	490
			90	6.2	47	178	2955	84	475
			100	6.9	50	189	3166	90	472
CHX5000	Carbon Steel	704777	40	2.8	55	208	4124	117	561
			50	3.4	63	238	5547	157	659
			60	4.1	68	257	6741	191	747
CHX5000-SS-LNG	Stainless Steel	704778	70	4.8	73	276	7452	211	761
			80	5.5	80	303	8366	237	788
			90	6.2	84	318	8133	230	729
			100	6.9	87	329	8635	245	747
CHX15000	Carbon Steel	704779	40	2.8	106	401	9066	257	643
			50	3.4	123	466	12243	347	745
			60	4.1	133	503	15779	447	891
			70	4.8	144	545	16319	462	848
			80	5.5	155	587	17945	508	869
			90	6.2	163	617	18265	517	849
CHX20000	Carbon Steel	704780	40	2.8	195	738	11145	316	428
			50	3.4	219	829	13702	388	468
			60	4.1	237	897	15151	429	479
CHX20000-SS-LNG	Stainless Steel	704781	70	4.8	263	996	17558	497	499
			80	5.5	273	1033	17989	509	494
			90	6.2	293	1109	19161	543	490
			100	6.9	314	1189	21095	597	503
CHX27000	Carbon Steel	704783	40	2.8	188	712	19459	551	774
			50	3.4	205	776	23028	652	842
			60	4.1	218	825	24819	703	850
			70	4.8	234	886	26844	760	860
			80	5.5	246	931	27080	767	823
			90	6.2	263	996	27316	774	787
			100	6.9	275	1041	27552	780	750

Notes: 1. Chemguard C2 2% concentrate should not be used for salt water applications.
2. Chemguard C2 2% and C2-S 2% concentrates should not be mixed for normal system operation.

System Calculation for Total Flooding

Building

- Light steel construction
- Non-sprinklered

Hazard

- Low density combustibles

Fill Time

As stated in NFPA 11, the fill time for a non-sprinklered building of light steel construction and a hazard of low density combustibles is a maximum of 3 minutes (T).

Building Area

100 ft (30.5 m) × 30 ft (9.1 m) = 3,000 ft² (278 m²)

Building Height

10 ft (3 m) = Volume (V) of 30,000 ft³ (850 m³)

Calculation Without Sprinklers

$$\begin{aligned} R &= (V/T) \times C_N \times C_L \\ R &= \text{Rate of Discharge in cfm} \\ V &= \text{Submergence Volume in ft}^3 \\ T &= \text{Submergence Time in minutes} \\ C_N &= \text{Compensation for normal shrinkage} \\ &\quad (1.15, \text{ constant}) \\ C_L &= \text{Compensation for leakage} \\ &\quad 1.0, \text{ no leakage} \\ &\quad 1.2, \text{ moderate leakage} \\ R &= (30,000 \text{ ft}^3 / 3 \text{ min}) \times 1.15 \times 1 = \\ &\quad 10,000 \times 1.15 \times 1 \\ &= 11,500 \text{ cfm required} \end{aligned}$$

11,500 cfm / 6,741 cfm per CHX5000 @ 60 psi
= 1.71 generators

Metric Calculation

$$\begin{aligned} R &= (850 \text{ m}^3 / 3 \text{ min}) \times 1.15 \times 1 \\ &= 283.3 \times 1.15 \times 1 \\ &= 326 \text{ cmm required} \end{aligned}$$

326 cmm / 191 cmm per CHX5000 @ 4.1 bar
= 1.71 generators

Therefore, use two CHX5000 generators at 6,741 cfm (191 cmm) each.

System Calculation for Local Application

Group II aircraft hangar using outside air to generators.

Hangar to be protected

- Group II hangar measuring 33,000 ft² (3066 m²)
- Sprinkler system (wet pipe) for 0.17 gpm/ft² over 5000 ft² (6.9 Lpm/m² over 465 m²)

Fill time

As stated in NFPA 409, fill depth of 3 ft (0.9 m) within one minute (T) with sufficient foam concentrate for 12 minutes total.

Building Area

150 ft × 220 ft = 33,000 ft² (45.7 m × 67.1 m = 3066 m²)

Foam Volume (V)

33,000 ft² × 3 ft = 99,000 ft³ (2803 m³)

Calculation With Sprinklers

$$\begin{aligned} R &= ([V/T] + R_s) \times C_N \times C_A^* \times C_L \\ R_s &= \text{Rate of foam breakdown by sprinklers} \\ &\quad 10 \text{ cfm/gpm} \times \text{sprinkler system discharge in} \\ &\quad \text{gpm (0.075 cmm/Lpm} \times \text{sprinkler discharge} \\ &\quad \text{in Lpm)} \\ C_N &= \text{Compensation for normal shrinkage} \\ &\quad (1.15 \text{ constant}) \\ C_A^* &= \text{Compensation for inside air} \\ &\quad (1.20 \text{ constant}) \\ C_L &= \text{Leakage factor (not required for local} \\ &\quad \text{application systems)} \\ R &= ([99,000 \text{ ft}^3 / 1 \text{ min}] + 8500 \text{ cfm}) \times 1.15 \\ &= 107,500 \times 1.15 \\ &= 123,625 \text{ cfm minimum required} \end{aligned}$$

123,625 cfm / 26,844 cfm per CHX27000 @ 70 psi
= 4.61 generators

Metric Calculation

$$\begin{aligned} R &= ([2803 \text{ m}^3 / 1 \text{ min}] + 241 \text{ cmm}) \times 1.15 \\ &= 3044 \times 1.15 \\ &= 3501 \text{ cmm minimum required} \end{aligned}$$

3501 cmm / 760 cmm per CHX27000 @ 4.8 bar = 4.61 generators

Therefore, use five CHX27000 generators at 26,844 cfm (760 cmm) each.

Inside air may be used with AHJ approval. When using inside air, Johnson Controls recommends using the 20% compensation factor (C_A^) noted in the calculation for R. Contact Johnson Controls Technical Services with questions on use of inside air for high-expansion foam systems.

Ordering Information

Standard Models (Carbon Steel Construction)

Part Number	Generator Model	Weight		C2 2% Approvals
		lb	(kg)	
703603	3000WP	115	(52)	UL, CE
704775	CHX2000	73	(33)	UL, CE
704777	CHX5000	255	(116)	UL, CE
704779	CHX15000	397	(180)	UL, CE
704780	CHX20000	398	(180)	UL, CE
704783	CHX27000	720	(327)	UL, CE

LNG Models (Stainless Steel Construction)

Part Number	Generator Model	Weight		Approvals
		lb	(kg)	
704776	CHX2000-SS-LNG	73	33	UL, CE
704778	CHX5000-SS-LNG	255	255	UL, CE
704781	CHX20000-SS-LNG	398	180	UL, CE

CHX27000 Dimensions

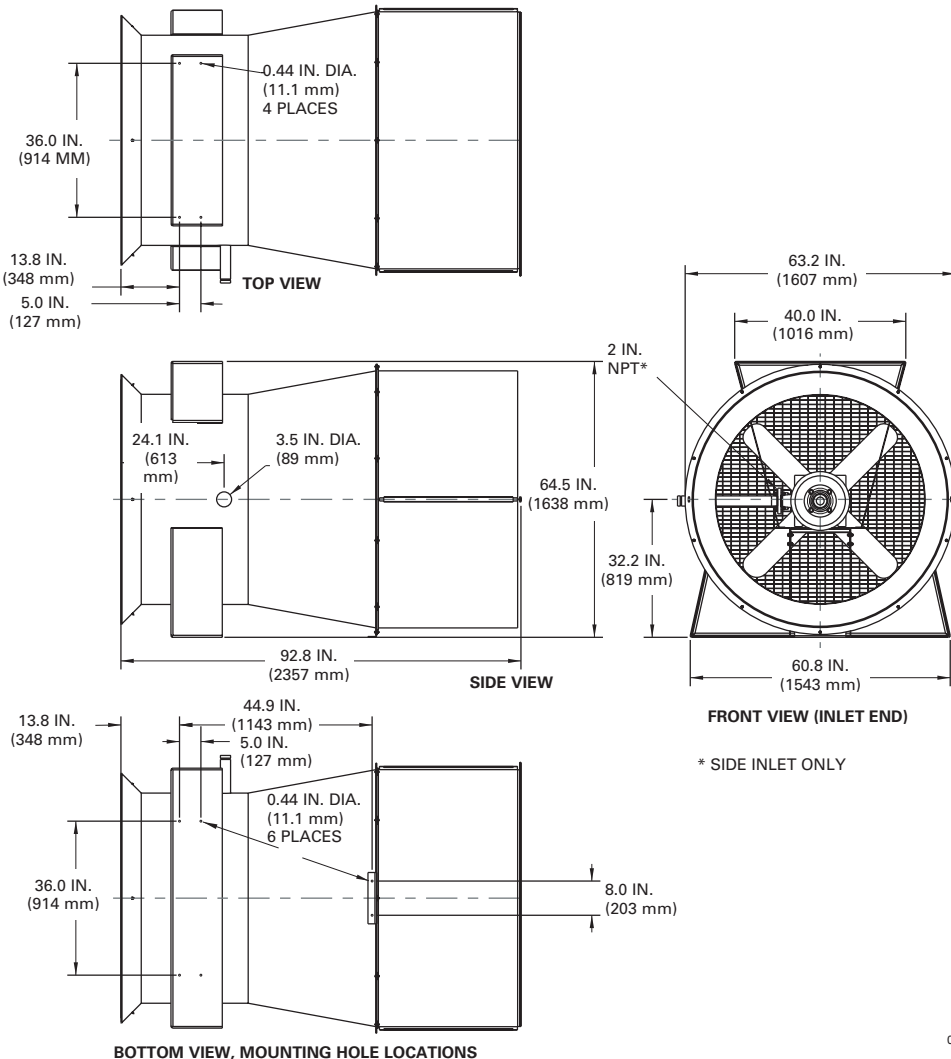

008417

Note: The converted values in this document are provided for dimensional reference only and do not reflect an actual measurement. CHEMGUARD and the product names listed in this material are trademarks and/or registered trademarks. Unauthorized use is strictly prohibited.

General Dimensions

CHX5000

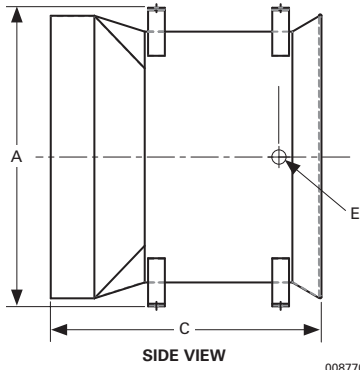

008770

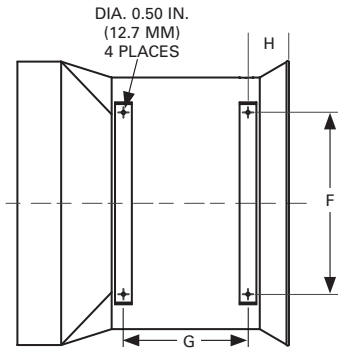

008769

CHX2000, CHX15000, CHX20000

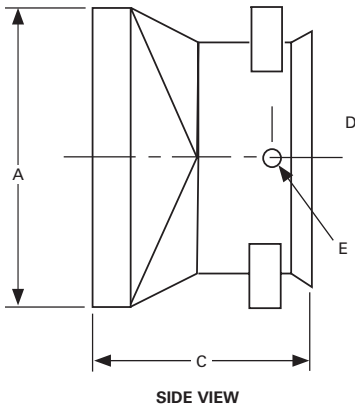

006371

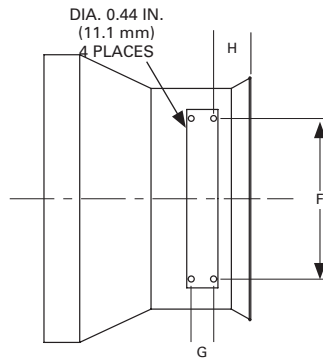

All Square Outlet Models

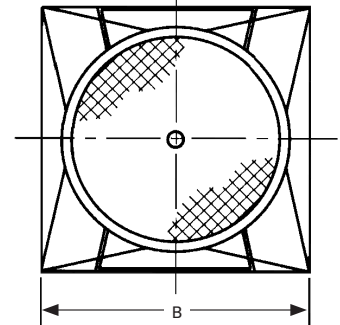

001275

Model	A		B		C		D		E	F		G		H	
	in.	(mm)	in.	(mm)	in.	(mm)	in.	(mm)	NPT - in.	in.	(mm)	in.	(mm)	in.	(mm)
CHX2000	25.0	(635)	25.0	(635)	30.1	(764)	3.9	(99)	1.0	16.0	(406)	-	-	3.3	(83)
CHX5000	44.5	(1130)	42.1	(1069)	40.3	(1024)	6.4	(154)	1.5	27.0	(686)	18.5	(470)	6.1	(156)
CHX15000	64.0	(1629)	64.0	(1629)	46.0	(1178)	8.5	(219)	2.0	36.0	(914)	5.0	(127)	8.0	(213)
CHX20000	64.0	(1629)	64.0	(1629)	46.0	(1178)	8.5	(219)	2.0	36.0	(914)	5.0	(127)	8.0	(213)

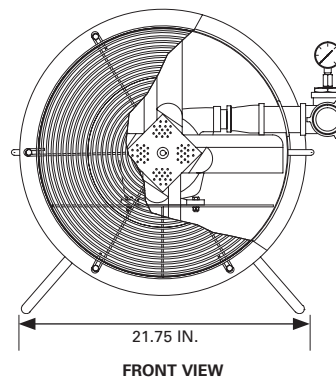
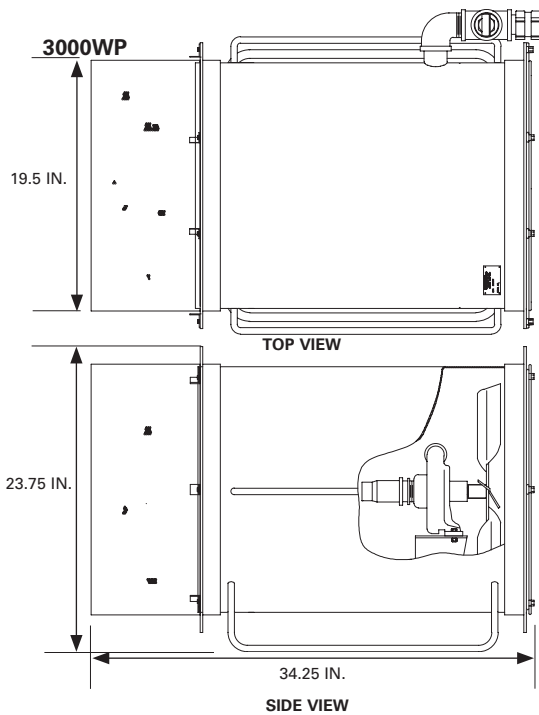

010366